

# EZ2Wire - E8 Wiring Harness

## Installation Manual

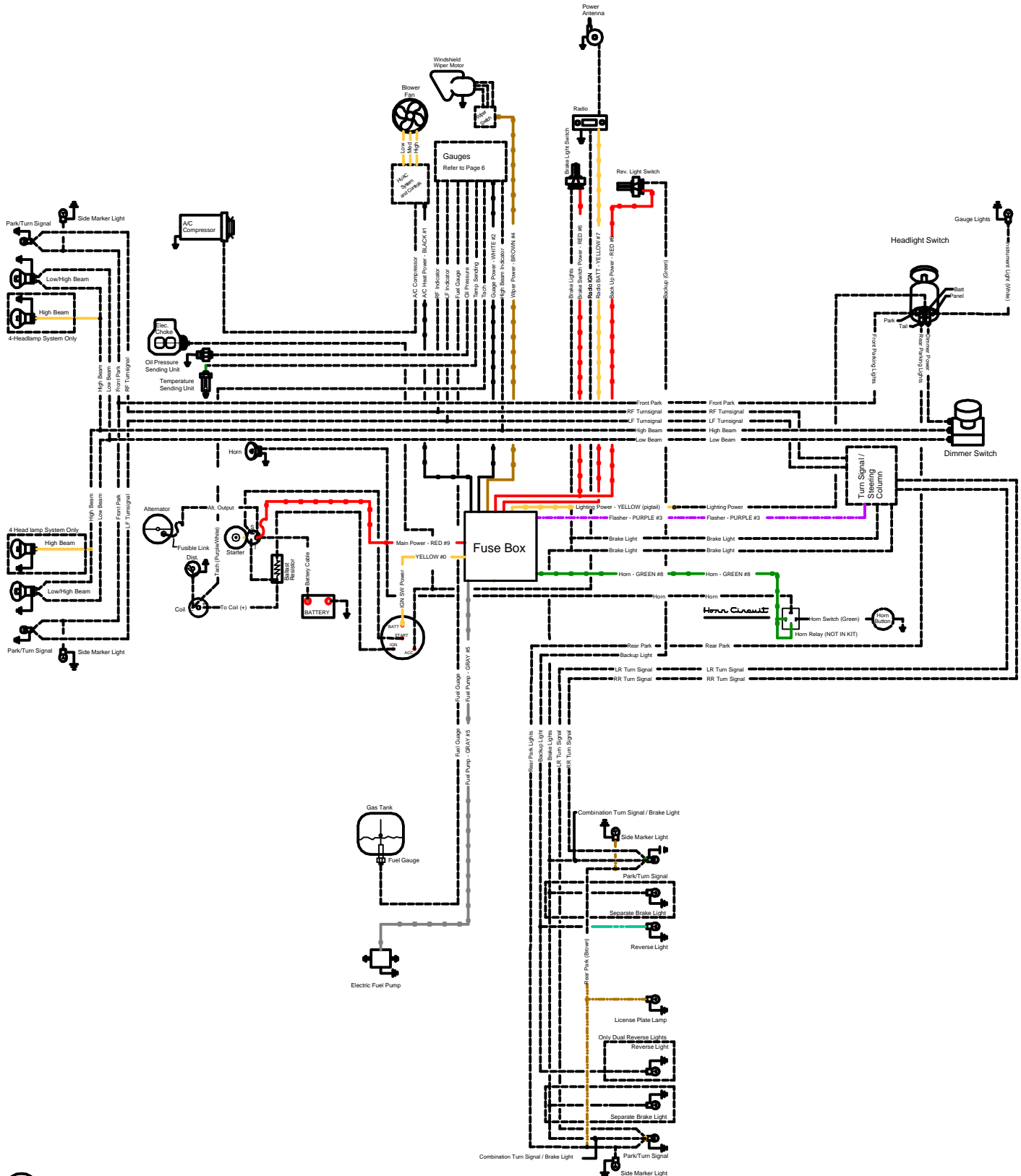

# EZ2Wire GM12 & GM21 Diagram and Instruction Manual

---

## Index:

- i - Index, Instructions, and Guidelines
- ii - Guide and Checklist
- 1 - Fuse Box Diagram
- 2 - Front Wiring Diagram
- 3 - Dash Harness Diagram
- 4 - Column Harness Diagram
- 5 - Rear Wiring Diagram

## Circuits and Fuses

<u>Circuit:</u>	<u>Amps:</u>
#1 - AC Heat	20
#2 - Ignition	15
#3 - Turn Signals	15
#4 - Wipers	30 (CB)
#5 - Fuel Pump	20
#6 - Brake/Back-Up	15
#7 - Horn	10
#8 - Radio (Batt)	5

## Notes:

1. In retrofit applications refer to your factory wiring diagram to properly rewire model specific systems such as: A/C, Wiper motor, etc.
2. Diagram represents the wiring as sent to you with the kit. Many wires are not included in the kit. Such as ground, control wires, supplemental wires, etc.

## Legend:

-----  Ground Wire

----- Wire not in harness



Bulb

## EZ2Wire E8 Instructions

---

- 1 - Remove battery
- 2 - Find a Good Metal Surface to mount the Fuse Panel
- 3 - Mount the Fuse Panel with sheet metal screws or other metal fasteners
- 4 - Make sure to run the screw through the small ring terminal in the upper left hole into a clean metal connection (If the ringlet is not properly grounded, the wiring harness will not function correctly)
- 5 - Remove only the straps or tape holding the main bundles together, leaving the individual bundles together for later use.
- 6 - Never Use a Fuse Larger than 25 amps in any circuit of this harness
- 7 - It is not recommended to change any of the fuses in the fuse panel to a larger size, doing so may damage the harness.

## EZ2Wire Checklist

---

- 1 - Don't let the size of the project overwhelm you, really it's EZ2Wire
- 2 - Refer to the factory wiring diagram if one exists
- 3 - Use the diagrams provided with after-market or specialty accessories
- 4 - If installing an Amp Meter to follow the directions in the dash diagram
- 5 - Before you start installing the harness remove the battery from the vehicle
- 6 - Start one section, then one circuit at a time.
- 7 - Install a main ground cable from the engine to the frame
- 8 - Have the main body ground cable the same size as the battery cable
- 9 - Remember to ground all accessories
- 10 - Do not route wires over sharp objects
- 11 - Do not route wires where they could possibly interfere with moving parts
- 12 - Do not attempt to lengthen wires by stretching them to make them reach
- 13 - Use cable ties to help loom and sort the harness
- 14 - Use a wire loom cover where harness is exposed, especially in the engine bay
- 15 - Route all wires before making final connections.
- 16 - Fasten the Harness down with clamps and ties to keep it secure
- 17 - Use grommets when passing wires through holes in sheet metal
- 18 - Use insulated terminals or heat shrink over the connections
- 19 - Use the correct terminals and connectors for the gauge of wire
- 20 - Do not overcrimp the terminals and connectors
- 21 - Be sure to install a fusible link, circuit breaker or fuse at the alternator
- 22 - When harness installation is complete place the battery in the vehicle but  
**ONLY CONNECT THE POSITIVE (+) to the Battery**
- 23 - **DO NOT CONNECT THE NEGATIVE TERMINAL (-) TO THE BATTERY**
- 24 - Follow the directions & perform a circuit test before you make the final connection
- 25 - Remember these are generic directions, modify them as needed for your vehicle
- 26 - Be sure to keep notes and mark them on these directions when done
- 27 - Save these directions so you will have them in the future

To Dash Harness

To Front Harness

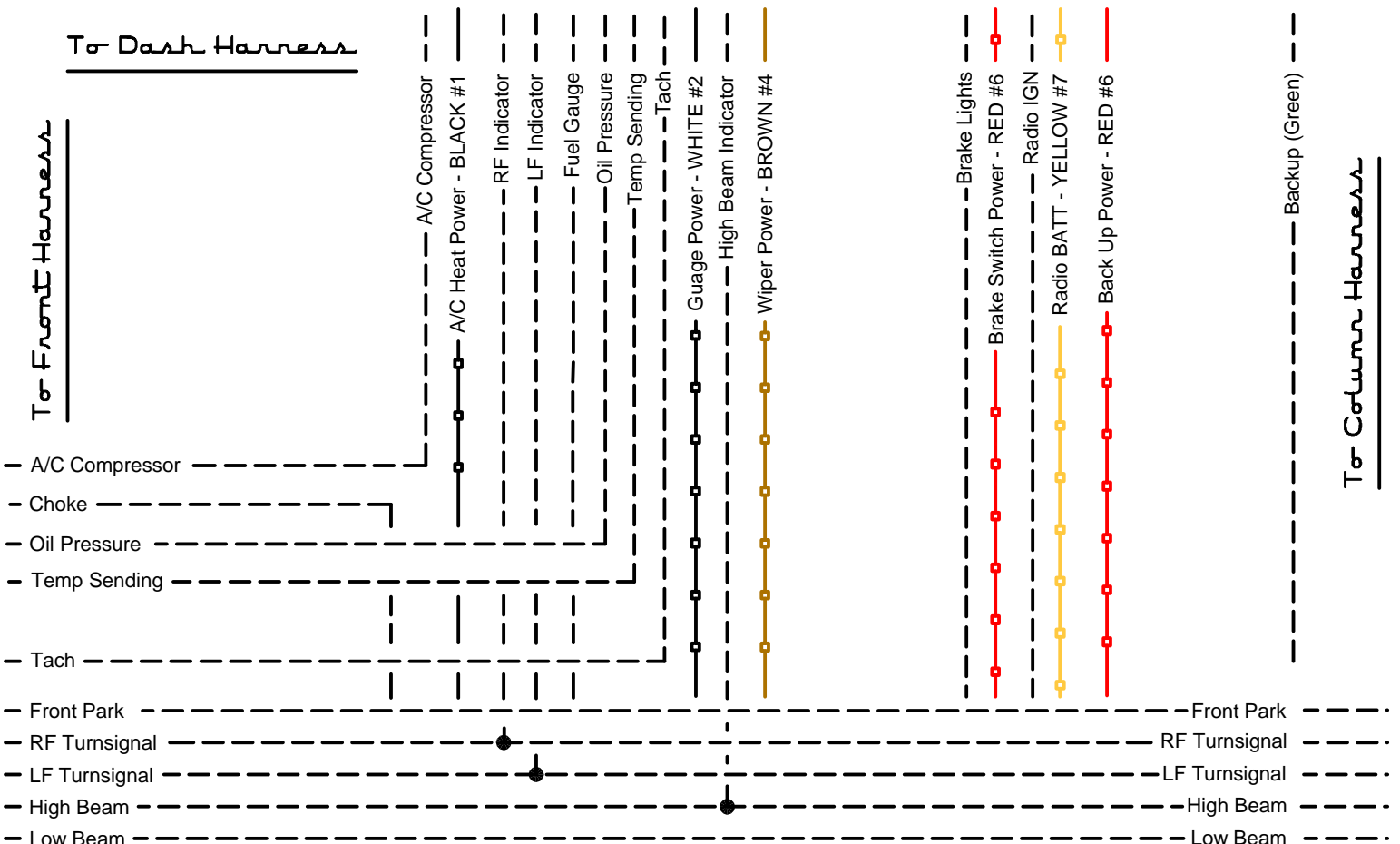

To Column Harness

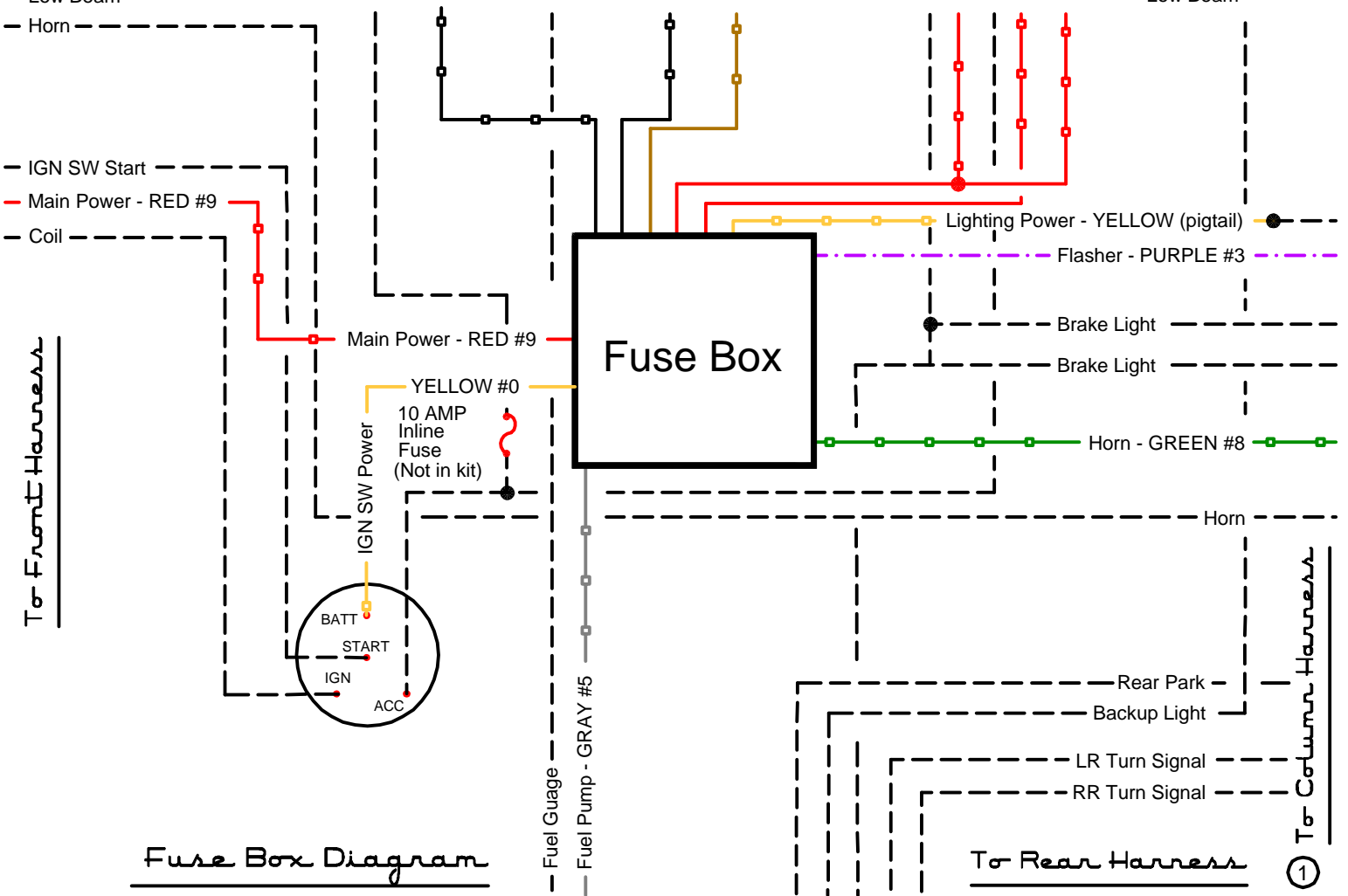

To Front Harness

To Column Harness

Fuse Box Diagram

To Rear Harness



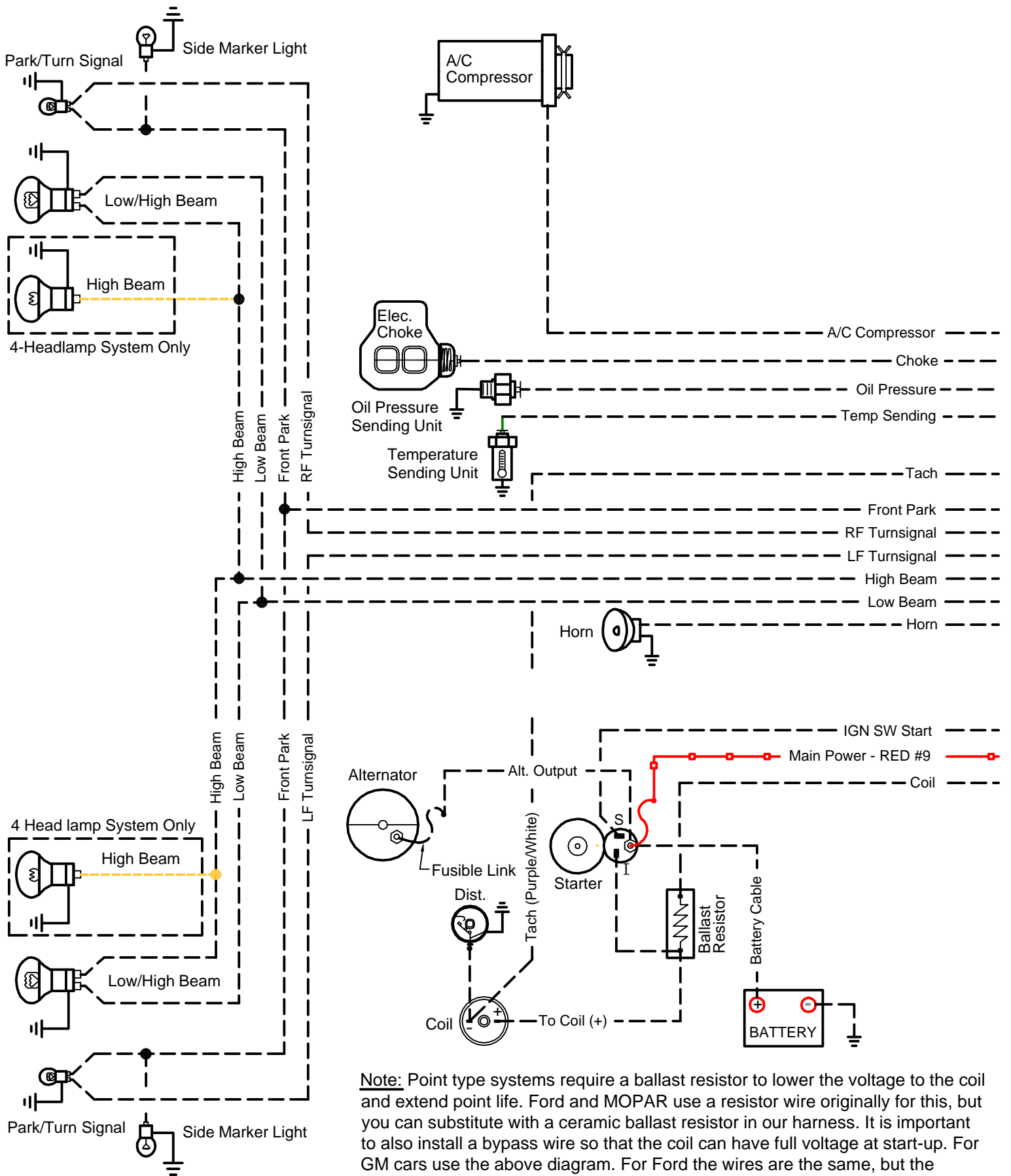

**Note:** Point type systems require a ballast resistor to lower the voltage to the coil and extend point life. Ford and MOPAR use a resistor wire originally for this, but you can substitute with a ceramic ballast resistor in our harness. It is important to also install a bypass wire so that the coil can have full voltage at start-up. For GM cars use the above diagram. For Ford the wires are the same, but the bypass comes from the start solenoid terminal marked I. MOPAR runs the bypass wire from the starter relay terminal marked IGN

## Front Wiring Diagram

# Dash Wiring Diagram

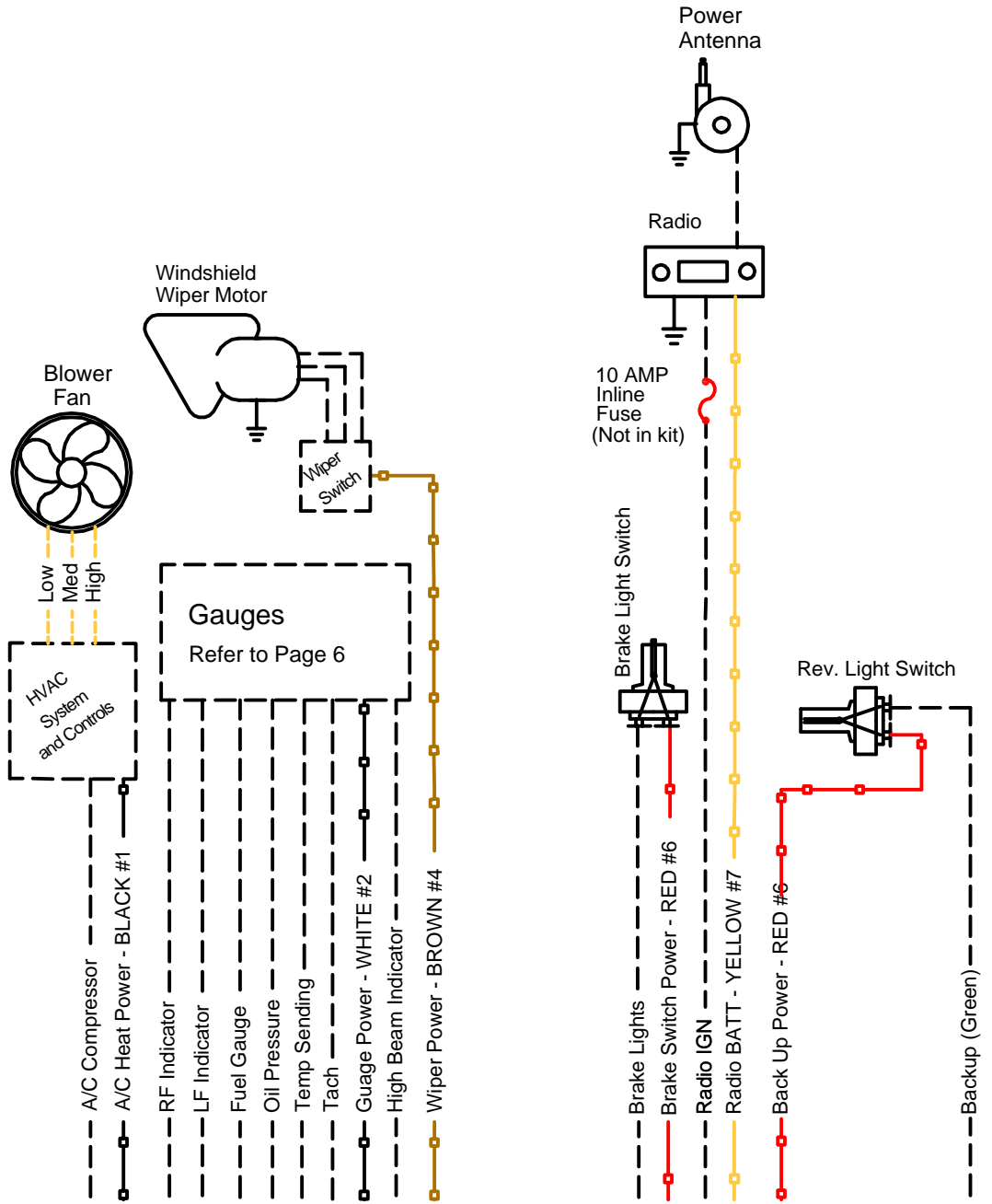



## Neutral Cut Off Switch

If you have a Neutral Safety Switch (Primarily Automatic Equipped Vehicles), You will cut the ignition switch start wire and attach both ends to the each connector on the Neutral Safety Switch. End at the S of the Terminal on the starter, or where the IGN SW Start (YELLOW #0) wire is terminated at the starter relay.

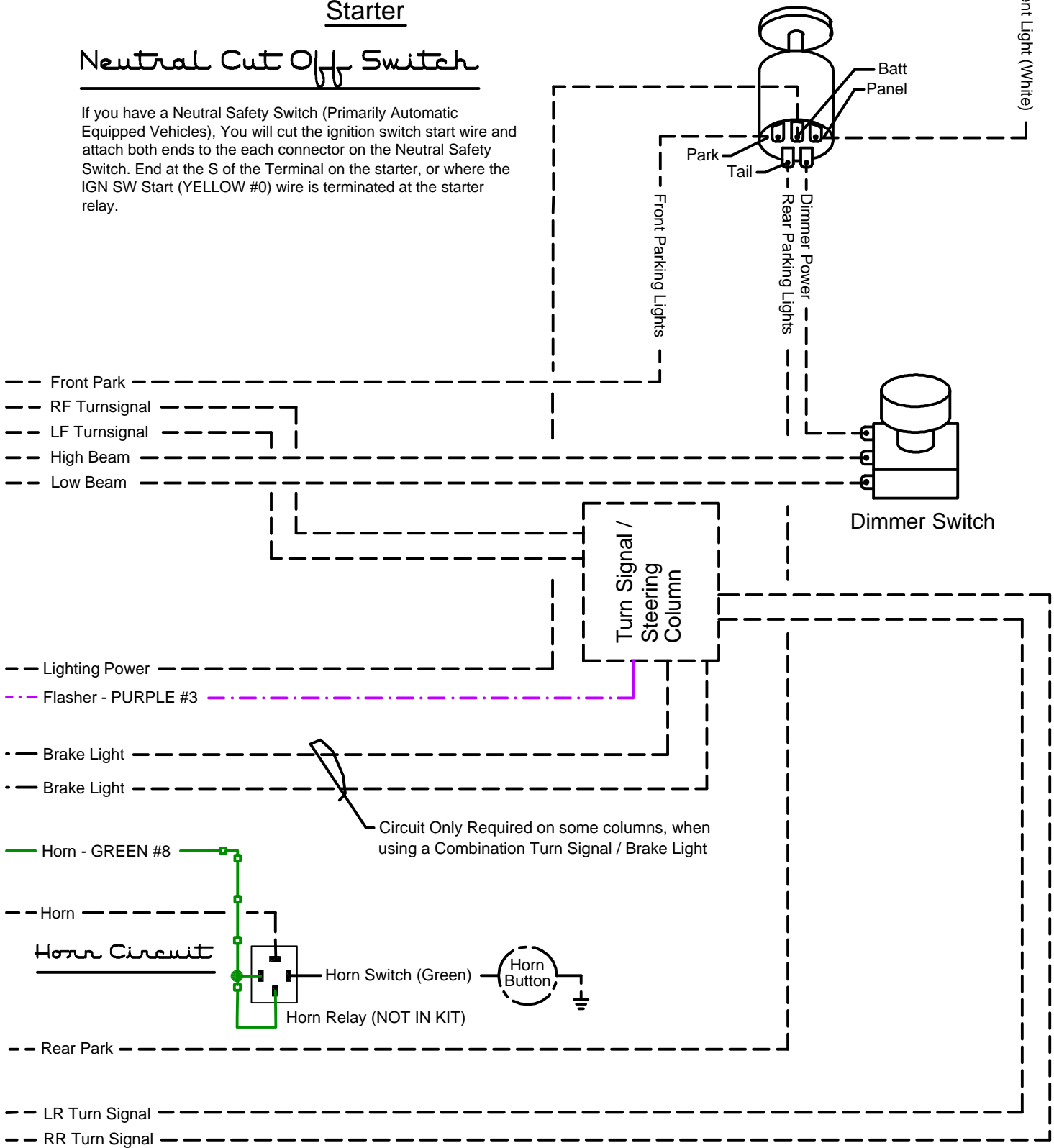

## Column Wiring Diagram

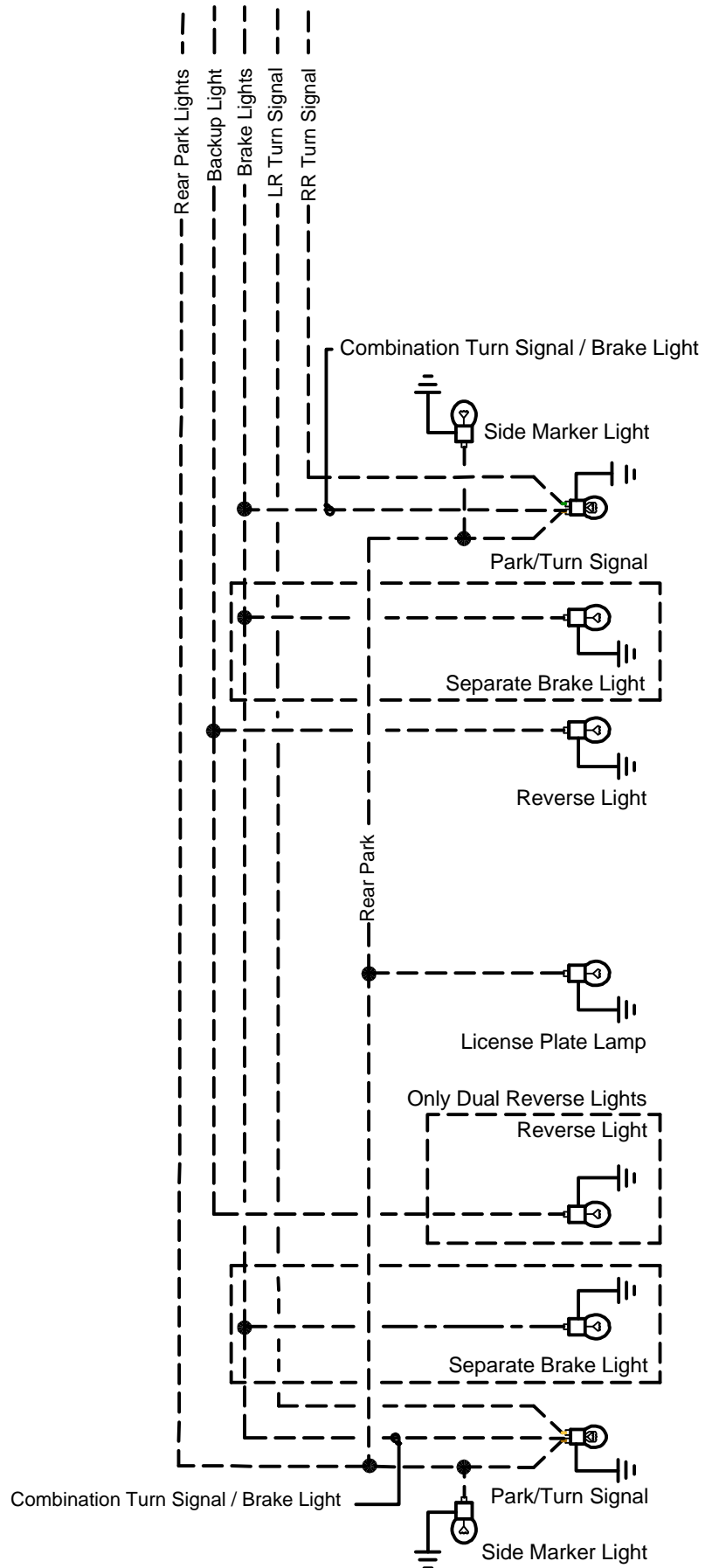
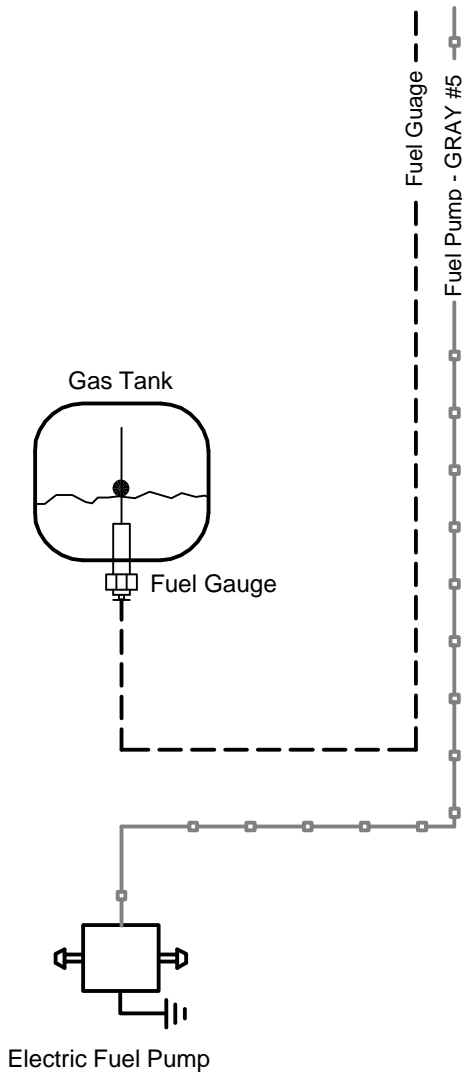

Rear Wiring Diagram